

# TRUCK CRANE

## TL-300M

*JAPANESE SPECIFICATIONS*

TL

CARRIER MODEL	OUTLINE	SPEC. NO.
NISSAN DIESEL P-KG45S	1-Motor 2-Drum Winch (Standard Specifications)	TL-300M-1-10101
	2 Single Winches (Option)	TL-300M-1-10102

Control No. JA-01

# TL-300M

## CRANE SPECIFICATIONS

### CRANE CAPACITY

10.6m Boom	30,000kg	at 3.5m	(10 part-line)
14.5m Boom	23,000kg	at 4.0m	( 8 part-line)
18.4m Boom	18,000kg	at 5.5m	( 8 part-line)
22.3m Boom	14,000kg	at 6.5m	( 5 part-line)
26.2m Boom	13,000kg	at 6.5m	( 5 part-line)
30.1m Boom	10,000kg	at 7.0m	( 4 part-line)
34.0m Boom	8,000kg	at 8.0m	( 4 part-line)
9.0m Jib	3,000kg	at 75°	( 1 part-line)
15.0m Jib	2,000kg	at 77°	( 1 part-line)
Single top	3,000kg		( 1 part-line)

### MAX. LIFTING HEIGHT

Boom	33.9m
Jib	48.7m

### MAX. WORKING RADIUS

Boom	32.0m
Jib	38.9m

### BOOM LENGTH

10.6m - 34.0m

### BOOM EXTENSION

23.4m

### BOOM EXTENSION SPEED

23.4m / 112s

### JIB LENGTH

9.0m, 15.0m

### MAIN WINCH SINGLE LINE SPEED

High range:	122m/min	(4th layer)
Low range:	61m/min	(4th layer)

### MAIN WINCH HOOK SPEED

High range:	12.2m/min	(10 part-line)
Low range:	6.1m/min	(10 part-line)

### AUXILIARY WINCH SINGLE LINE SPEED

High range:	104m/min	(2nd layer)
Low range:	52m/min	(2nd layer)

### AUXILIARY WINCH HOOK SPEED

High range:	104m/min	(1 part-line)
Low range:	52m/min	(1 part-line)

### BOOM ELEVATION ANGLE

-3° - 80°

### BOOM ELEVATION SPEED

-3° - 80° / 60s

### SWING ANGLE

360° continue

### SWING SPEED

3.1rpm

### WIRE ROPE

Main Winch

16mm × 185m (Diameter × Length)  
 7 × 7 + 6 × Fi(29) Class B ordinary · Z twist  
 Spin-resistant wire rope  
 Breaking strength 17.6t

Auxiliary Winch

16mm × 105m (Diameter × Length)  
 7 × 7 + 6 × Fi(29) Class B ordinary · Z twist  
 Spin-resistant wire rope  
 Breaking strength 17.6t

### BOOM

4-section hydraulically telescoping boom of box construction.  
 (stage 2: sequential; stages 3,4: synchronized)

### BOOM EXTENSION

2 double-acting hydraulic cylinder  
 1 wire rope type telescoping device

### JIB

2-staged swingaround boom extension which stores alongside boom base section  
 Dual offset (5°, 30°) type.

### SINGLE TOP

Single sheave. Mounted to main boom head for single line work.

### HOIST

Driven by hydraulic motor and via spur gear speed reducer. With free-fall device.

Automatic brake (with foot brake for free-fall device)

1-Motor 2-Drum Winch ..... Standard Specifications

Two Single Winches ..... Option

### BOOM ELEVATION

1 double-acting hydraulic cylinders

### SWING

Hydraulic motor driven planetary gear reducer

Swing bearing

Hand brake

Swing free/lock changeover type

### OUTRIGGERS

Fully hydraulic H-type (floats mounted integrally)

Slides and jacks each provided with independent operation device.

Full extended width 6.1m

Middle extended width 4.0m

### FRONT JACK

Hydraulic operated type

### MAX. OUTRIGGER LOAD

31.3t

### HYDRAULIC PUMPS

3 gear pumps

### HYDRAULIC OIL TANK CAPACITY

432 liters

### SAFETY DEVICES

Automatic moment limiter (AML-K2)

Over-winding cutout

Level gauge

Over front area control device

Working area control device

Hook safety latch

Winch drum lock

Hydraulic safety valve

Telescopic counterbalance valve

Elevation counterbalance valve

Jack pilot check valve

Front jack over load alarm

### EQUIPMENTS

Crane cab heater

Boom angle indicator

Jib extending device

Radio

Fan

## CARRIER SPECIFICATIONS

### MANUFACTURER

NISSAN DIESEL MOTOR CO., LTD

### CARRIER MODEL

P-KG455

### ENGINE

Model PE6 (with turbo)

Type 4-cycle, in-line 6-cylinder, direct-injection water-cooled diesel engine

Piston displacement 11,670cc

Max. output 280PS at 2,200rpm

Max. torque 110kg·m at 1,200rpm

### CLUTCH

Dry single-plate coil spring type

### TRANSMISSION

6-forward and 1-reverse speeds

Constant-mesh gear (1st speed, reverse)

Synchronized-mesh gear (2nd - 6th speeds)

### REDUCER

Hypoid gear type

### FRONT AXLE

Reverse Elliot-type steel pipe cross section

### REAR AXLE

Full floating, cast torque rods

### SUSPENSION

Front Laminated leaf spring type

Rear Equalizer and torque rods

### STEERING

Recirculating ball screw type with linkage power assistance

### BRAKE SYSTEM

Service Brake

2-circuit hydro-pneumatic type, 8-wheels internal expanding brake

Parking Brake

Mechanically operated, duo-servo shoe type acting on drum at transmission case rear.

Auxiliary Brake

Electro-pneumatic operated exhaust brake

### ELECTRIC SYSTEM

24 V DC. 2 batteries of 12V (120Ah)

### FUEL TANK CAPACITY

200 liters

### CAB

Two-man type

### TIRES

Front 11.00-20-14PR

Rear 10.00-20-14PR

### STANDARD EQUIPMENTS

Car heater

Car radio

## GENERAL DATA

### DIMENSIONS

Overall length 12,660mm

Overall width 2,490mm

Overall height 3,390mm

Wheel base 1,520mm + 3,530mm + 1,300mm = 6,350mm

Tread Front 2,020mm

Rear 1,860mm

### WEIGHTS

Gross vehicle weight

Total 31,600kg

Front 12,300kg

Rear 19,300kg

### PERFORMANCE

Max. traveling speed 60km/h

Gradeability (tan  $\theta$ ) 0.36

Min. turning radius 10.5m

# TOTAL RATED LOADS

(1)

Unit : ton

· Outriggers fully extended + Front jack (360°) · Outriggers fully extended (Over rear · Over sides)														
A B (m)								C						
	10.6 m	14.5 m	18.4 m	22.3 m	26.2 m	30.1 m	34.0 m	9.0 m		15.0 m				
								E (°)	D		5°	30°	5°	30°
3.0	30.00	23.00	18.00						80	3.00	1.60	2.00	0.90	
3.5	30.00	23.00	18.00	14.00				78	3.00	1.60	2.00	0.90		
4.0	26.60	23.00	18.00	14.00	13.00			77	3.00	1.60	2.00	0.85		
4.5	23.70	21.90	18.00	14.00	13.00			76	3.00	1.60	1.92	0.80		
5.0	21.40	20.80	18.00	14.00	13.00	10.00		75	3.00	1.55	1.82	0.77		
5.5	19.40	19.20	18.00	14.00	13.00	10.00	8.00	70	2.28	1.40	1.49	0.69		
6.0	17.70	17.50	16.70	14.00	13.00	10.00	8.00	65	1.85	1.21	1.25	0.62		
6.5	16.20	16.00	15.55	14.00	13.00	10.00	8.00	60	1.49	1.12	1.02	0.58		
7.0	14.80	14.60	14.55	13.55	12.25	10.00	8.00	55	1.10	0.87	0.74	0.53		
7.5	13.45	13.25	13.25	12.70	11.55	9.60	8.00	50	0.81	0.67	0.54	0.40		
8.0	12.40	12.35	12.30	11.95	10.95	9.15	8.00	45	0.51	0.47	0.38	0.30		
9.0	10.20	10.00	10.00	10.40	9.75	8.35	7.40	43	0.37	0.35	0.28	0.24		
10.0		8.40	8.35	8.85	8.75	7.65	6.70	41	0.26	0.23				
12.0		5.95	5.90	6.35	6.65	6.45	5.55							
12.5		5.45	5.40	5.85	6.15	6.15	5.30							
14.0			4.25	4.70	4.95	5.20	4.65							
16.0			3.10	3.55	3.80	4.00	3.90							
16.5			2.80	3.25	3.50	3.75	3.75							
18.0				2.70	2.95	3.15	3.30							
20.0				2.00	2.25	2.45	2.60							
20.5				1.85	2.10	2.30	2.50							
22.0					1.75	1.95	2.10							
24.0						1.30	1.65							
24.5						1.20	1.55							
26.0							1.30							
28.0							0.80	1.00						
28.5							0.70	0.95						
30.0								0.75						
32.0								0.45						

- A = Boom length
- B = Working radius
- C = Jib length
- D = Jib offset
- E = Boom angle

**NOTES:**

1. The total rated loads shown are for the case when the outriggers are set horizontally on firm ground. The values are based on the crane strength.
2. The weights of slings and hooks (main winch hook: 350kg, auxiliary winch hook: 60kg) are included in the total rated loads shown.
3. The total rated load is based on the actual working radius including the deflection of the boom.
4. The number of part lines for each boom length should not exceed the values below. The load per line should not exceed 3.0 tons for both the main winch and the auxiliary winch.

A	10.6 m	14.5 m	18.4 m	22.3 m	26.2 m	30.1 m	34.0 m	J
H	10	8	8	5	5	4	4	1

A = Boom length H = No. of part-line J = Jib / Single top

5. The total rated loads for free-fall operations is 1/5 of the total rated loads given above. The load per line should not exceed 0.6 ton for both the main winch and the auxiliary winch.
6. The total rated loads for the single top are obtained by subtracting the corresponding values below from the total rated load of the main boom and must not exceed 3.0t.

A	10.6 m	14.5 m	18.4 m	22.3 m	26.2 m	30.1 m	34.0 m
Q	0 kg	150 kg	150 kg	250 kg	250 kg	300 kg	300 kg

A = Boom length Q = Subtracted load

(2)

Unit : ton

· Outriggers middle extended (360°) · Outriggers fully extended (Over front)							
A \ B (m)	10.6m	14.5m	18.4m	22.3m	26.2m	30.1m	34.0m
3.0	30.00	23.00	18.00				
3.5	30.00	23.00	18.00	14.00			
4.0	25.50	23.00	18.00	14.00	13.00		
4.5	20.80	19.20	18.00	14.00	13.00		
5.0	16.40	16.20	16.00	14.00	13.00	10.00	
5.5	13.80	13.60	13.40	14.00	13.00	10.00	8.00
6.0	11.90	11.70	11.50	12.00	12.30	10.00	8.00
6.8	9.40	9.20	9.00	9.50	9.80	10.00	8.00
7.0	9.00	8.80	8.65	9.15	9.40	9.65	8.00
7.8	7.30	7.15	7.00	7.50	7.75	8.00	8.00
8.0	7.00	6.85	6.70	7.20	7.45	7.70	7.85
9.0	5.50	5.45	5.40	5.85	6.10	6.35	6.50
10.0		4.40	4.30	4.75	5.00	5.25	5.40
12.0		2.90	2.75	3.20	3.50	3.70	3.85
12.5		2.55	2.50	2.95	3.20	3.40	3.55
14.0			1.75	2.20	2.45	2.70	2.80
16.0			0.95	1.45	1.70	1.95	2.10
16.5			0.75	1.30	1.55	1.80	1.90
18.0				0.80	1.20	1.40	1.50
19.0				0.55	0.90	1.15	1.25
20.0					0.65	0.90	1.05
21.0						0.70	0.90

A = Boom length B = Working radius

**NOTES:**

1. The total rated loads shown are for the case when the outriggers are set horizontally on firm ground. The values are based on the crane strength.
2. The weights of slings and hooks (main winch hook: 350kg, auxiliary winch hook: 60kg) are included in the total rated loads shown.
3. The total rated load is based on the actual working radius including the deflection of the boom.
4. The number of part lines for each boom length should not exceed the values below. The load per line should not exceed 3.0 tons for both the main winch and the auxiliary winch.

A	10.6 m	14.5 m	18.4 m	22.3 m	26.2 m	30.1 m	34.0 m	Single top
H	10	8	8	5	5	4	4	1

A = Boom length H = No. of part-line

5. The total rated loads for free-fall operations is 1/5 of the total rated loads given above. The load per line should not exceed 0.6 ton for both the main winch and the auxiliary winch.
6. The total rated loads for the single top are obtained by subtracting the corresponding values below from the total rated load of the main boom and must not exceed 3.0t.

A	10.6 m	14.5 m	18.4 m	22.3 m	26.2 m	30.1 m	34.0 m
Q	0 kg	150 kg	150 kg	250 kg	250 kg	300 kg	300 kg

A = Boom length Q = Subtracted load

## WORKING RADIUS - LIFTING HEIGHT

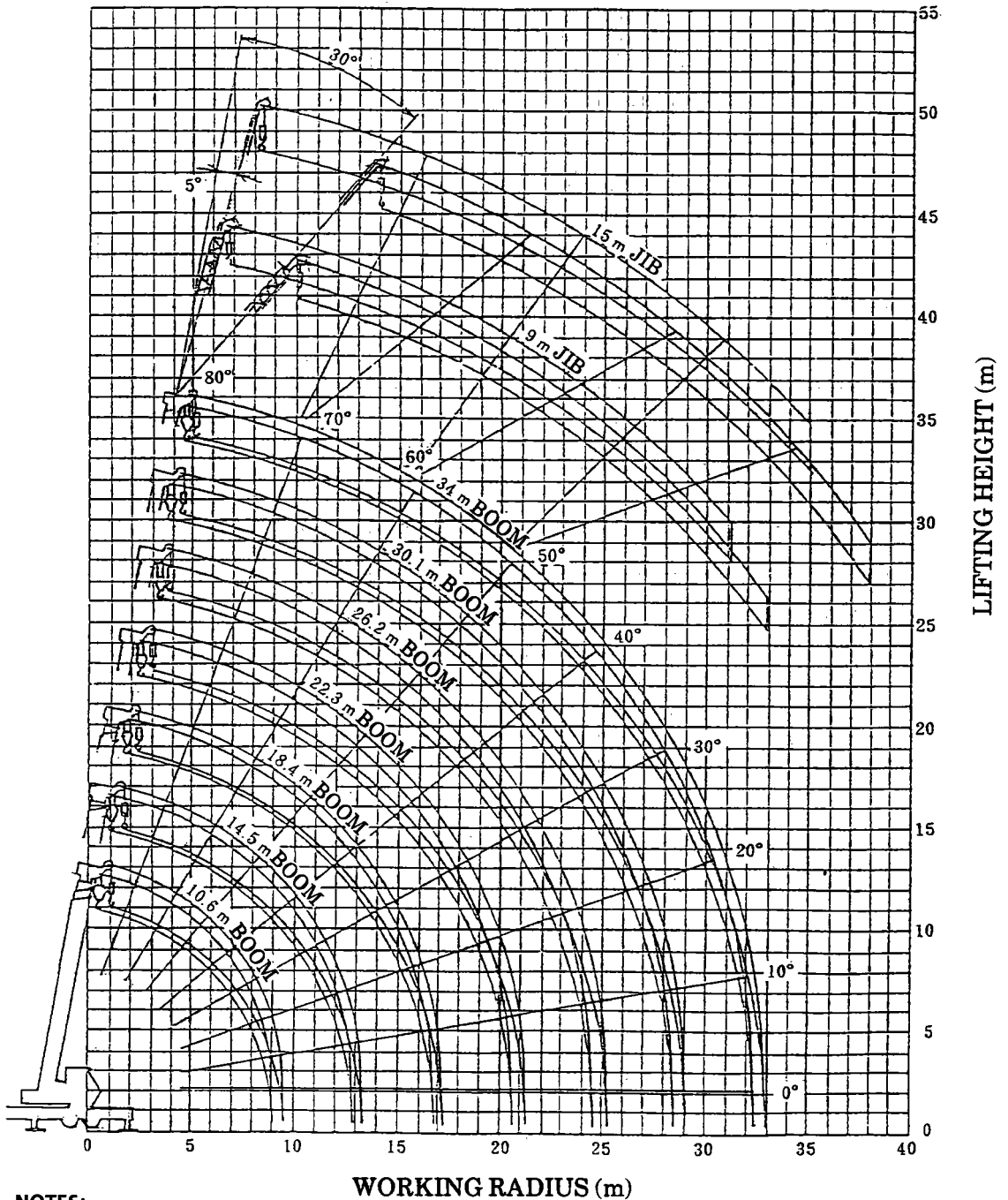

**NOTES:**

1. The deflection of the boom is not incorporated in the figure above.
2. The above chart is for the case where the outriggers are fully extended and where the front jack are used (over 360°).

**DIMENSIONS (1/100)**

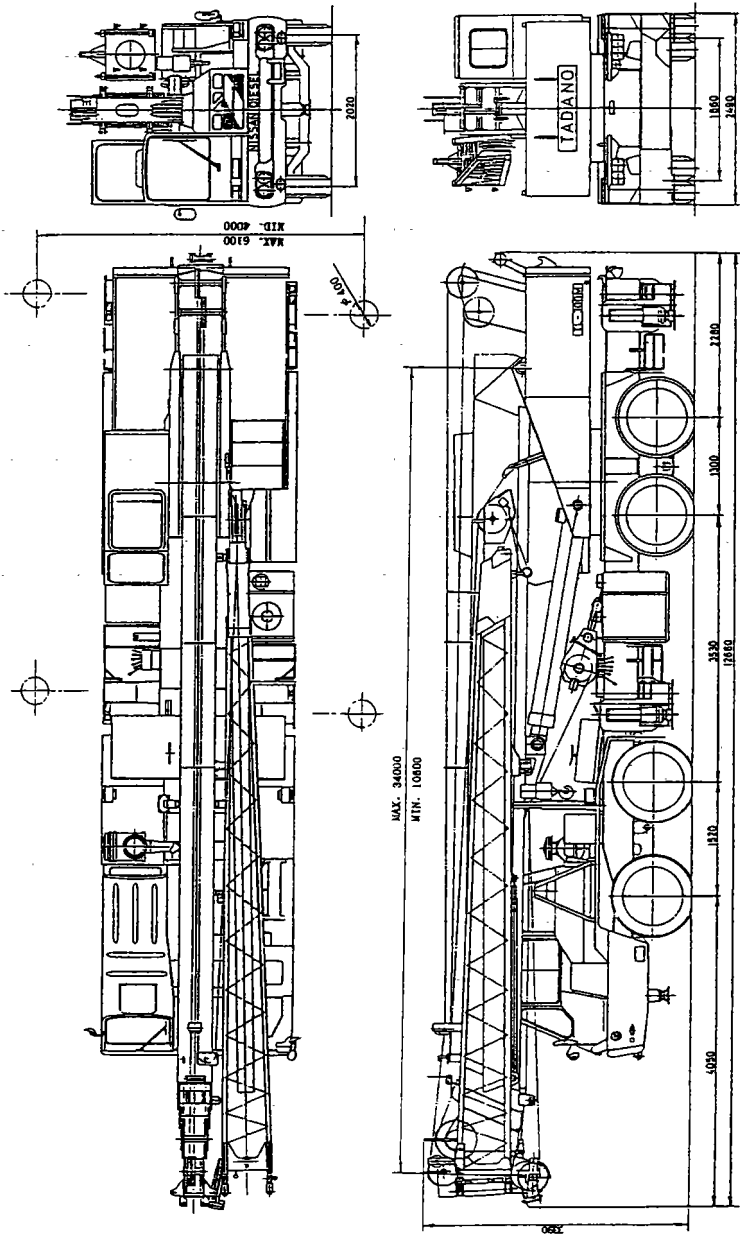

◆ MEMO ◆

A series of horizontal dashed lines for writing.